

Model for Water Quality Monitoring Based on Internet of Things

Soka Zimba^{1,2} and Christopher Chembe¹

1. School of Computing, Technology and Applied Sciences, ZCAS University.
Email: {soka.zimba, christopher.chembe}@zcasu.edu.zm.
2. Department of ICT Studies, National Institute of Public Administration (NIPA), Lusaka, Zambia.

Abstract

In Lusaka, water pollution has been a problem for many decades, which has led to outbreaks of various waterborne diseases such as cholera, dysentery, and many more. In this research, we proposed a water quality monitoring system based on the Internet of Things (IoT). IoT relies on sensors to measure different parameters in water and report the results in real-time. The real-time information obtained from sensors through the IoT system can be used to warn users if there is any contamination in the water before the community gets infected. The deliverables for this research project are 1) Water quality monitoring using IoT sensors; 2) a dashboard to show water analysis from sensors, and 3) a mobile application to notify users should there be contamination of water. The results were obtained through the testing of water collected from various sources. Others results collected are dairy gold milk, undiluted Coolsplash juice and combination of other mixture. The results obtained show that IoT technology can be used to detect water quality. The model design has demonstrated to be effective based on the results obtained from the experiments. The proposed prototype can be used to help monitor water quality in Zambia.

Keywords: Water Quality, IoT, Sensors, Water Contamination, Mobile Application

1. INTRODUCTION

Due to the aquifer's vulnerability, bacteria, nitrates, ammonium, and other contaminants have been widely introduced into Lusaka's groundwater[1]. Since 1977, cholera outbreaks have been a recurring issue, with the most recent outbreak occurring in 2017–2018[2]. Cholera is becoming more prevalent worldwide, with the bulk of cases (60%) happening in sub-Saharan Africa. Since 1977, epidemics have mostly affected the capital city of Lusaka. The Ministry of Health acted quickly to curb the outbreak's spread and contain it during both the 2016 and 2018 outbreaks[3]. Usually, communities with polluted drinking water and inadequate sanitization systems report epidemics. IoT systems may be used in Lusaka to monitor water quality and provide the community with early warnings. Additionally, if there is pollution in the water supply, the community might be alerted in real-time to take measures. In Lusaka, there has been a severe problem with water quality, with practically annual reports of water contamination events. Africa should pay attention to water monitoring since it may be used to track long-term changes in water quality, spot emerging

issues, and develop successful intervention plans to address water pollution[4]. The Lusaka Water Supply and Sanitation Company (LWSC), the Ministry of Health (MoH), and over 220 randomly selected drinking water sources in both cholera-affected and -unaffected communities were tested in January 2018. Daily findings were reported to the MoH, NPHI, and LWSC[2]. This study aimed to discover a long-term solution to the problem of polluted water before illnesses arose. Through the dashboard, the usage of sensors in conjunction with mobile applications can assist the community in being warned when the water is polluted. The timing of this study corresponds with an increase in the incidence of water-borne illnesses in some parts of Lusaka, as well as a lack of other techniques to identify water pollution before it reaches consumers. It should be able to provide data for future investigations to generate additional knowledge on the research issue, collect information that will be beneficial in educating the audience. The purpose of this study was to investigate the possibility of using IoT to monitor the quality of water and how the technology may aid in the detection of water pollution. Water samples from various places such as Meanwood Kwamwena Valley and the National institute of public administration (NIPA) were collected and evaluated with turbidity, total dissolved solids (TDS), and PH levels.

A. Research Objectives

This research aims at assessing the current water monitoring mechanism used by the National Water Supply and Sanitation Council (NWASCO). To create and implement the prototype for water quality monitoring based on IoT. To create a dashboard for water quality monitoring. To develop a mobile application to alert end users of possible water contamination.

B. Research Questions

What are the current water quality monitoring mechanisms used by NWASCO? How can IoT be used in water quality and monitoring? How can a dashboard be used to inform stakeholders of monitoring water quality? Can a mobile application be used to alert stakeholders of any water contamination?

2. Literature review

A network of actual objects is known as the IoT. This idea was first put out by Kevin Ashton from the Massachusetts Institute of Technology in 1999. The Internet of Everything, machine-to-machine (M2M), ubiquitous computing, and embedded Internet systems are examples of related technologies.[5] The testing of particles in water is very important because the flavour of water can be influenced by the presence of dissolved particles[6]. The palatability of drinkable water was assessed by taster panellists as follows: excellent taste would be less than 300 mg/litre, acceptable is between 300 and 600 mg/litre, moderate is somewhere between 600 and 900 mg/litre, poor is between 900 and 1200 mg/litre, and unsatisfactory is greater than 1200 mg/litre.[6]. Palatable means the fact or quality of being acceptable or agreeable to the taste according to dictionary.com. Water can have an acidic, alkaline, or neutral pH. The pH scale runs from 0 to 14, with pH 7 signifying neutral water [7]. Water with a higher level of alkalinity is not good for health as well as Acidic [8]. Currently, in Zambia, testing of water quality is done manually, and adopting the use of the IoT in water monitoring is the best method. Water quality monitoring (WQM) is a low-cost and efficient system that uses IoT technology to track drinking water quality. Contaminated water is responsible for around 40% of all fatalities worldwide[9]. WQM is comprised of multiple sensors that can monitor a variety of environmental conditions, including pH, turbidity in the waters, tank levels, temperatures, and humidity. Water quality monitoring is critical for managing the physical, chemical, and biological aspects of water. Little progress has been made in Zambia on sensors for monitoring water quality via the internet of things.[10] Contaminant wastewater loads from mines, industry and agriculture activities dumped into the Kafue River System deteriorated the river's quality of water[11]. [9] [12] researched a 'smart water quality monitoring system using cost-effective IoT. WQM is a cost-effective and efficient system that uses IoT technology to monitor drinking water quality. The study provided a system block made up of multiple sensors that can detect various parameters, as illustrated in figure 1 below.

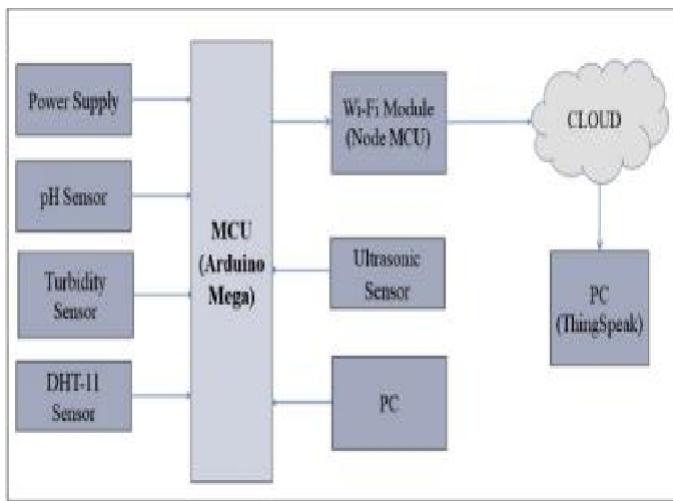

Fig 1: System block diagram[9]

[13]The internet of things (IoT) technology was used to perform research on water quality monitoring systems to monitor fish productivity to help overcome all the challenges. The project's goal was to identify the presence of fish using an ultrasonic sensor and to investigate the pH and temperature sensor parameters. The sensors interface with the NodeMCU ESP8266 microcontroller, which acts as an open-source IoT platform. It sent the data to the Blynk server, which was set up to store it.

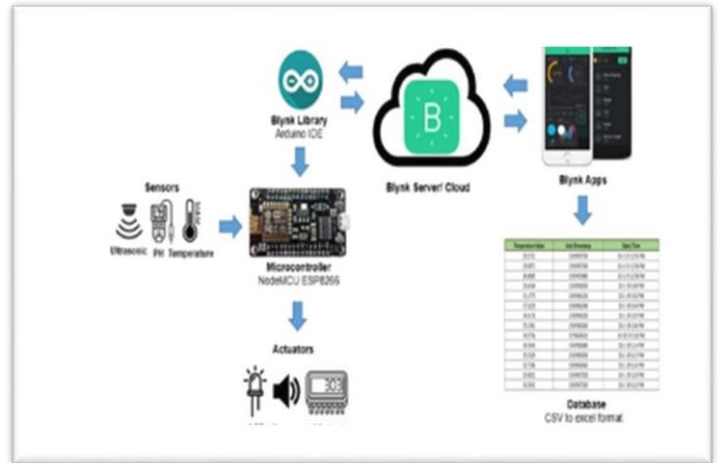

Fig 2: The System Project Outline [13]

A framework for managing sewer and water networks using sensor networks was created by researchers at the University of Zambia[14]. Satellite photos and updated maps of the sewage and water networks were created.

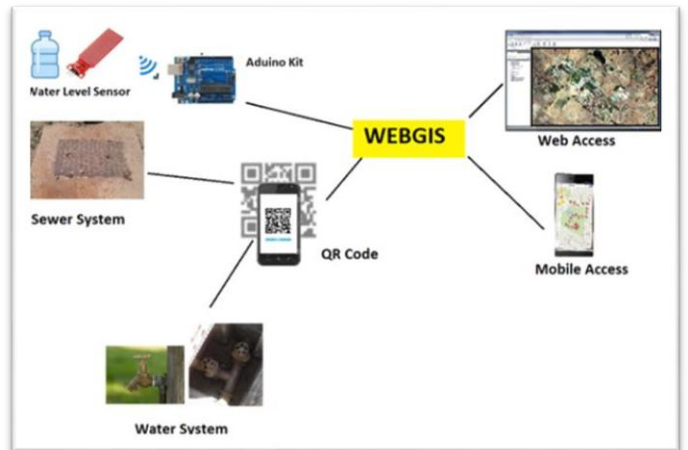

Fig 3: Proposed web GIS prototype [14]

The need for water monitoring to reduce pollution levels is growing.[15] Manual water quality surveillance methods in India significantly worsen water quality. Wireless Sensor Networks (WSN) are ideal for proactive water quality

control.[1] The technique provides a realistic solution for screening fecally contaminated drinking water in real-time across the world.[16]. Water is a necessary component for humanity's survival. Large reservoirs of water, such as lakes, streams, and the ocean itself, provide most of the world's supply. As a result, it's a good idea to keep an eye on its quality to make sure it's safe for human consumption. Water quality testing is now done in traditional labs, which is time intensive and prone to errors. [17]

3. Methodology and research design

A research design acts as the project's architectural plan, connecting design, data collecting, and analytic tasks to the research questions and guaranteeing that the entire study agenda will be covered [7]. In this kind of study, participants specify their issues and take part in creating the problem-solving strategy [7]. The goal of this research was to build a smartphone application that would make it easier to monitor drinking water and provide a solution to the problem of water quality monitoring. Figure 4 illustrates the method for planning applied research.

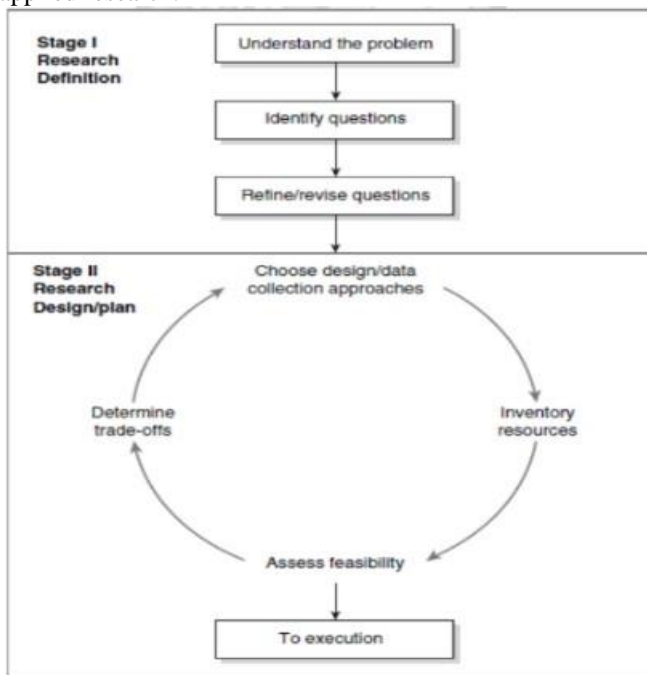

Fig 4: Planning applied research.[7]

To address the identified objectives, mixed methods were used as well as developing and deploying the Internet of Things (IoT) system.

3.3 Application of the methodology

In this research project, the study used the Rapid Application methodology (RAD), which was chosen as the best since it iteratively develops applications and produces systems more quickly and cheaply in projects with limited time[18]. Given the time limitations for designing the application, this methodology

was appropriate for our research. The methodology entails testing various liquid samples over the course of the development process to evaluate the results of each cycle. Figure 3 summarizes the RAD procedure.

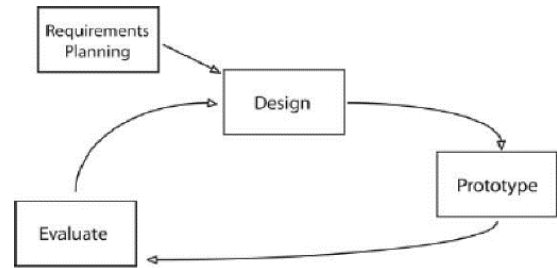

Fig 5: Rapid Application Methodology[18]

The methodology was applied in the IoT infrastructure framework. The areas of water quality that need monitoring were identified using secondary data. Following the collection of design information, the researcher developed the model including the mobile dashboard design recommendations using the software and hardware. As shown in figure 6, the section contains a variety of data collection tools and the justification for each one.

3.2 IoT Infrastructure framework

The data for the IoT infrastructure was collected using sensors as shown in figure 6 IoT Infrastructure framework.

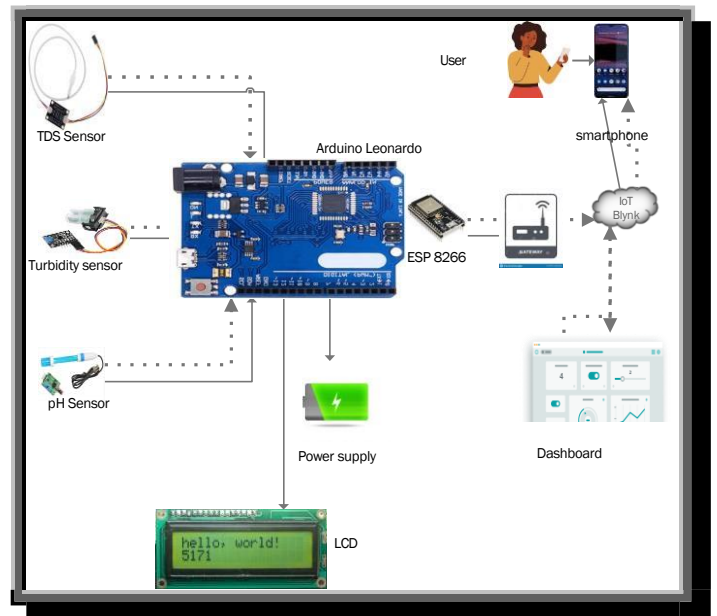

Fig 6: IoT-Based Water Monitoring System Architecture design.

3.4 Physical and Chemical Features of Water

Water turbidity is a factor of water quality that is dependent on the clearness or transparency of the water as well as the total suspended particles present. Planktons, algae, and other

suspended particles that are undetectable to the human eye generate turbidity, which influences the purity of water. The pH of the water should be between 0 and 14, and clean water should have a pH of 7.0.

3.5 Data Collection Instruments

Primary and secondary data were used in the study. The data was employed in the development of the different application components. The sources mostly provided information on the water quality characteristics that should be investigated, the difficulties with monitoring the water, and the shortcomings in existing models for monitoring water quality.

4. Design and implementation of IoT prototype

4.1 Assembly of Hardware

The hardware is at the heart of the programme. A breadboard 830 was used to connect the different sensors. Wire jumpers were used to link the sensors to the CPU through Arduino Leonardo R3.

4.2 Architecture for Applications

The modular system architecture outlines how the various components will interact with one another. The microcontroller receives data and sends it to the ESP8266 as an IoT gateway because it is used in a small environment. It sends sensor information to a cloud server through a wireless network connection, which is the Internet gateway (wireless router). Any microcontroller may connect to your Wi-Fi network with the ESP8266 Wi-Fi module, a self-contained system-on-chip (SOC) with an integrated TCP/IP protocol stack.

4.3 Designing a circuit

Figure 7 shows an example of a turbidity sensor, as well as how they were linked to the CPU.

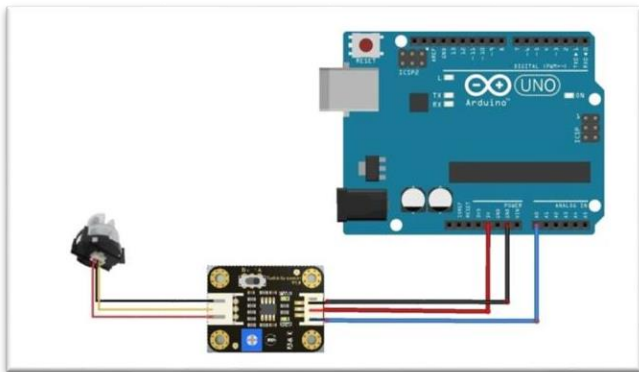

Fig 7: Example of Turbidity sensor wiring(how2electronics.com).

Figure 7 shows the connection of the turbidity sensor to the Arduino board. The black line is connected to GND, which is for negative power, and the red line, connected to VCC, is for 5 volts of positive power.

4.4 Experimental setup

Figure 8 depicts the experimental setup that was used.

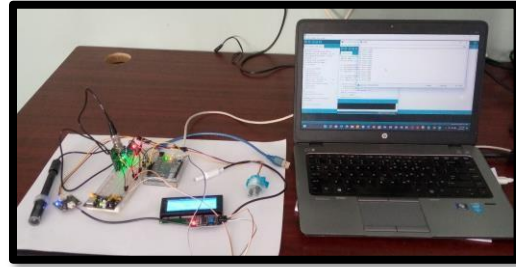

Fig 8: The assembly of the sensors, CPU, and microcontroller on the Breadboard.

The connections of the Arduino Leonardo 3, sensors, and LCD are shown in the tables below. Table 1 and 2 shows how the cables connected to the pins on the Breadboard and Arduino board. The turbidity sensor was connected to pin A0, which is the analogue pin to transfer data to the Arduino board example.

Table 1: The Interfacing pins of the Arduino and sensors

ARDUINO LEONARDO PIN	CABLE INTERFACE	SENSORS
A0	A	Turbidity
A1	Po	pH
A2	3	TDS
GND	GND	
V5	V5	

Table 2: The Interfacing pins of the Arduino and LCD.

ARDUINO PIN	LEONARDO	LCD PIN
SDA		SDA
SCL		SCL
GND		GND
V5		VCC

4.5 User Access

For the user to access and see the level of water quality, they have to login into a Blynk account created by the administrator who has the dashboard for the application. The user has to login using an email and password registered in Blynk on the web or mobile application.

4.6 Configuration of Software

A rapid prototyping tool for developing applications was the Blynk architecture. It allows you to develop project interfaces using a variety of widgets and interact with hardware via the phone's built-in Wi-Fi network. The libraries it offers cover a wide range of hardware platforms and facilitate command and control over devices.

4.7 Initial Setup

The system administrator, as the program's administrator, is the first person who gets access to the app via the Google Play store.

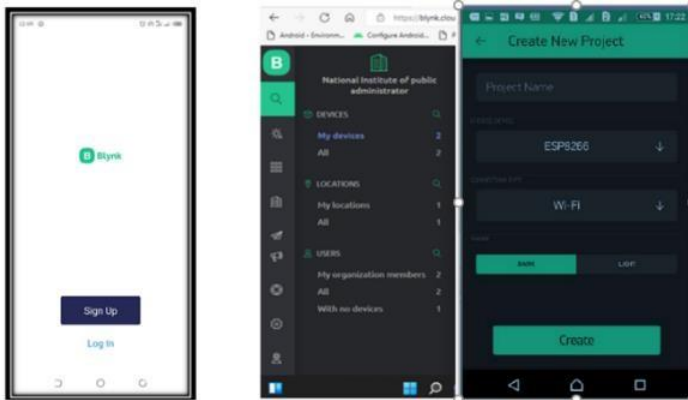

Fig 9: Blynk Mobile login and Dashboard

4.8 Designing of the Dashboard

Users will interact with application components using the graphic user interface seen on the application dashboard. The administrators can alter the widgets in the software based on the circumstances. Examples of dashboard design shapes are shown in Figure 9. Users may navigate the software using the widgets and choices on the dashboard[7].

4.9 Working model

Data collected by each sensor is shown on an LCD, web, and application downloaded on a Mobile phone. The measured data is transmitted and saved in the cloud via sophisticated Wi-Fi technology. With the help of Arduino Leonardo, the analogue signals from the sensors are transformed into digital signals.

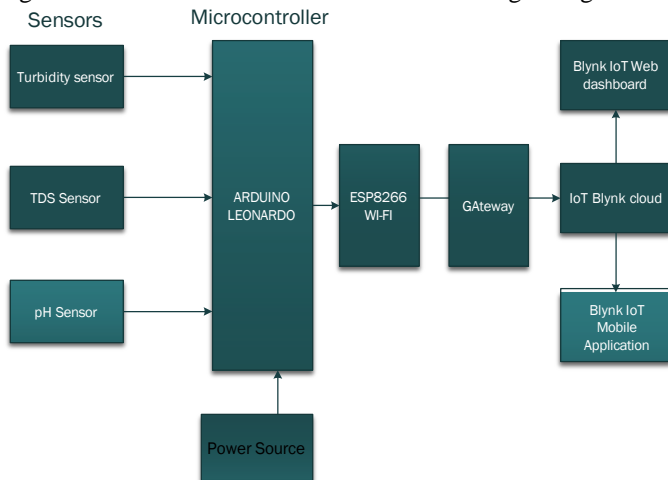

Fig 10: Block Diagram

4.10 Software

In order to run the system, the recommended software would show all the data gathered from the various sensors and save it on a cloud-based platform. The most appropriate interface is a mobile application because they are so widely available[19]. Additionally, using a mobile phone with the enhanced capabilities of the graphical interface [20].

4.11 Blynk Server

The most popular IoT platform for managing thousands of items, and remotely managing and monitoring devices connected to the cloud is called Blynk. For the examination of numerous sensors, including turbidity, pH, temperature, voltage, wetness, humidity, and distance, Blynk Server is an IoT data-gathering application. Data from edge node devices are gathered by the data collector, which also enables data modification for historical data analysis [9]. The functionality of the various sensor devices and other modules that make up the appropriate implementation model that we have identified are depicted in figure 10 above. The analogue-to-digital converter (ADC) will translate the relevant sensor reading to its digital value when sensors are attached to an Arduino Leonardo board for monitoring purposes.

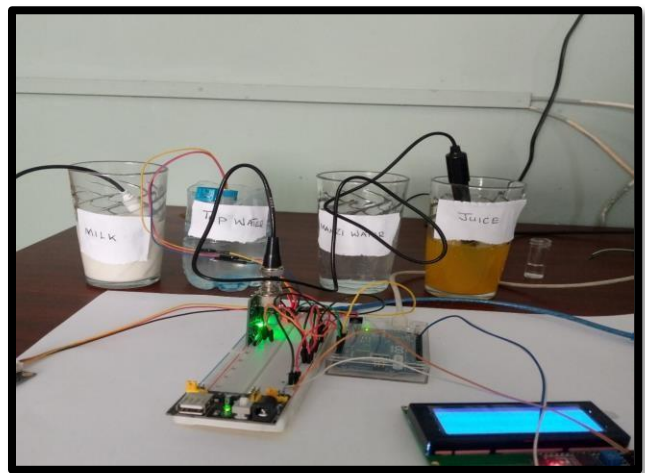

Fig 11: Testing of the samples collected.

Three sensors turbidity, pH, and TDS along with a microcontroller unit serving as the system's primary processing module and an ESP8266 Wi-Fi component for data transmission make up the system. The complete system is programmed in Embedded-C, and the Arduino IDE is used to imitate the written code. Data is gathered, saved, processed, and sent in real-time to the cloud IoT Blynk server.

5. Data Analysis and Results

A. Data Analysis

Data acquired from tests were reviewed to determine the degree of water quality on samples indicated in table 7, as well as to

assess current water monitoring technologies and make ideas for improvements.

Table 3: TDS Results for water quality.

Parameters	Acceptable Limit	unacceptable Limit	Manzi Valley	Meanwood Borehole	Dairy Gold Milk	Coolsplash Juice	NIPA Water	Mar Vall Plus
TDS (MG/L)	500	2000	133	416	1255	771	402	1

Water for NIPA shows a TDS of about 133ppm, whilst the borehole water collected from Meanwood Kwamwena valley shows a TDS of 416ppm. Thereafter, the researcher added 6 grams of salt in Manzi valley, and the TDS rose to 1903 ppm as shown in figure 12.

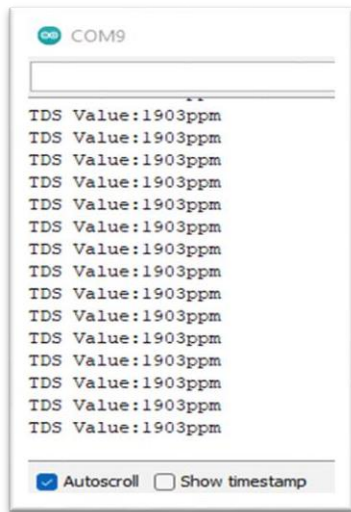

Fig 12: Test of Manzi valley water mixed with the salt of 6 grams monitored through the serial monitor.

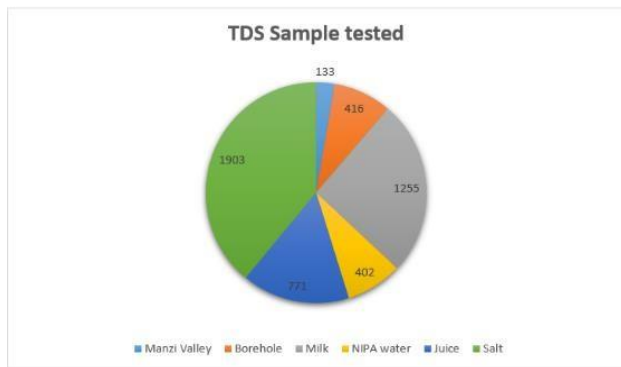

Fig 13: TDS results for different samples

Figure 13 shows the results of the samples tested for total dissolved solids in water using Arduino Leonardo with a TDS sensor. Salt with salt shows the highest total dissolved solids followed by Milk.

Table 4: Turbidity of the samples collected.

Parameters	Acceptable Limit	unacceptable Limit	Manzi valley	Meanwood Borehole	Dairy Gold Milk	Coolsplash Juice	NIPA Water	Manzi plus salt
Turbidity	5	100	34	35	96	46	34	35

Water with salt was also tested, which showed turbidity of 34 NTU (*Nephelometric Turbidity Units*), and undiluted juice showed 46 NTU. The sample of Dairy gold milk that was collected showed the highest level of turbidity - 96 NTU - on a display screen.

Table 5: The ranges of the Turbidity output.

NO.	TURBIDITY LEVEL	TSM(NTU)
1	Fair turbidity	15 – 25
2	Rather turbidity	25 – 35
3	Turbidity	35 – 50
4	Very turbidity	> 50

The turbidity ranges of water quality in this research are shown in table 5. The level of 15 to 25 means fair turbidity, and the level of 25 to 35 means rather turbidity. In addition, the range of 35 to 50 is turbidity, and above 50 is very turbidity.

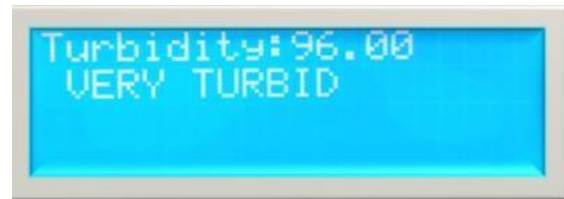

Fig 14: Turbidity of Milk monitored through LCD.

Figure 14 shows the 96 turbidity levels for Milk shown on the liquid crystal display.

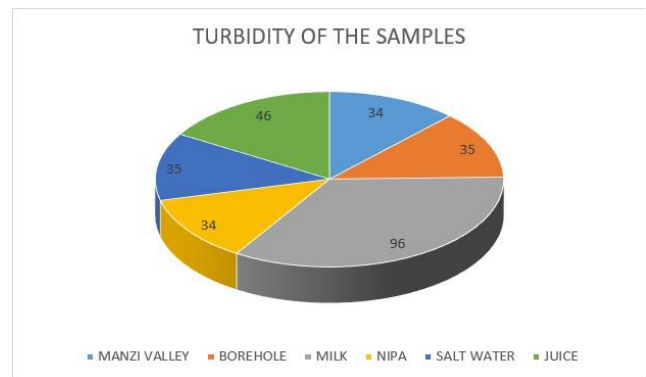

Fig 15: Turbidity levels

Figure 15 shows the levels of turbidity in the samples collected. Milk has the highest level of turbidity, followed by juice. The Manzi valley and NIPA have the lowest level of turbidity.

Table 6: pH Levels in liquid tested.

Parameters	Acceptable Limit	unacceptable Limit	Manzi valley	Borehole	Dairy gold Milk	Coolsplash Juice	NIPA Water	Manzi plus salt
pH	6.5 TO 8.5	14.0	8.01	7.84	7.31	4.51	8.27	8.39

Table 6 shows the level of pH in the liquid tested. Undiluted juice shows the lowest level of pH at 4.51, which means it is acidic as shown on the LCD below figure 16. The other samples show the liquids have a neutral pH level.

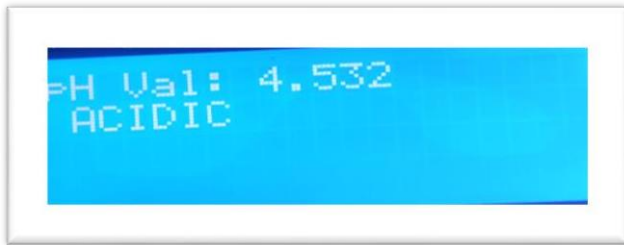

Fig 16: pH of Juice tested monitored through LCD.

Figure 16 shows the pH of undiluted juice, which indicates the level of pH in juice. It has a pH level of 4.532, which is acidic according to the results we got before calibration.

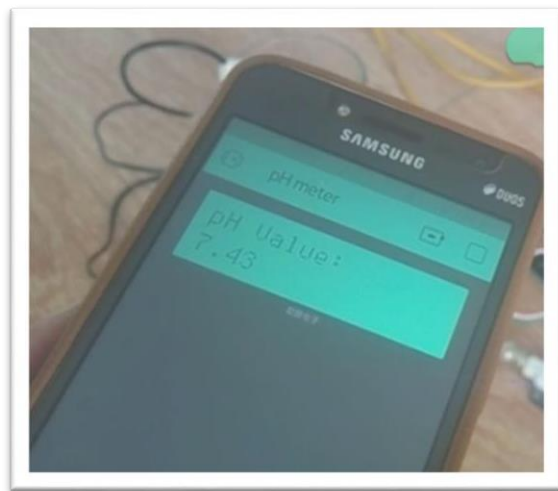

Fig 17: The pH meter monitored through the mobile phone.

Figure 17 shows the levels of PH for the samples tested for Manzi valley on the mobile phone.

B. Results/findings

Table 7: Results obtained from home sample

Parameters	Acceptable Limit	Unacceptable Limit	Manzi Valley	Meanwood Borehole	Dairy Gold Milk	Coolsplash Juice	Nipa borehole Water	Manzi Valley Plus Salt
TDS (MG/L)	500	2000	133	416	1255	771	402	1902
Turbidity	5	100	34	35	96	46	34	35
pH	6.5 TO 8.5	14.0	8.01	7.84	7.31	4.51	8.27	8.39

Table 7 above shows the results of the sample collected as shown in experiment figure 11. The samples of liquid tested are Manzi Valley water, borehole water collected from Meanwood, Kwamwena valley, Dairy Gold milk, undiluted Coolsplash juice, water from NIPA, and Manzi Valley mixed with the salt of 6 grams. The samples were tested for turbidity, total dissolved solids, and pH levels. The experiment conducted showed that the boreholes from both Meanwood Kwamwena valley and NIPA have high levels of total dissolved solids of about 416 and 402 compared to the purified water from Manzi valley, which has 133, which means the water has a low level of dissolved solids. These results mean that the Manzi Valley water is pure and clean. The other element tested was turbidity, which had the highest level of turbidity among the samples tested, with 96. A high level of turbidity is not acceptable because it means the water is polluted. According to the World Health Organisation, the turbidity, pH, and total dissolved solids in water for Meanwood, Kwamwena Valley, and NIPA findings are still acceptable because they are within the accepted range of water quality for drinking water. The level of turbidity of 96 for daily gold milk is not recommended for drinking water because it has a lot of particles in it. The pH level of pH 4.51 results obtained from undiluted Coolsplash juice is not recommended for drinking because it is highly acidic. This shows the author that the model designed is reliable and cheaper. Water quality testing will most likely be more cost-effective, convenient, and quick. The monitoring of turbidity, PH, and TDS in water was done with a water detection sensor that has a unique advantage and is already part of an IoT platform. The device can automatically monitor water quality, is low-cost, and does not require personnel to be on duty.

6. Discussion

Water quality monitoring can be achieved by designing and implementing the model proposed above. The simulation was intended to investigate how IoT may assist the NWASCO monitor water quality in real-time against conventional sample testing procedures. The model was designed to evaluate the amount of contamination in real-time. It also makes use of several sensors to improve water quality at a low cost.

7. Conclusions

NWASCO, as a regulatory body that utilizes Water utilities, conducts three sorts of tests, namely Physio-chemical, Bacteriological, and Residual Chlorine tests. In this research, the author designed and implemented a water quality monitoring tool prototype. The design is meant to measure physio-chemicals using sensors through the internet of things.

This can help to eliminate NWASCO for the use of physical or manual methods of tests of water samples.

8. Recommendations

We recommend investing in IoT technology to monitor water quality and the environment using sensors that can detect faecal matter, chemical oxygen demand (COD), chlorine, bacteria, and electrical conductivity, and detect changes in the environment. This will help to mitigate the impact of climate change on our environment. More sensors might be added to the model to make it a fully operating system.

Future Research: The system will be expanded to track hydrologic, fuel quality, air pollution, and industrial, and agricultural output, among other things. It has a wide range of applications and extensions.

Funding statement: This study was self-funded and did not receive any grants from public, private, or educational financing bodies.

9. References

- [1] K. M. Reaver *et al.*, "Drinking Water Quality and Provision in Six Low-Income, Peri-Urban Communities of Lusaka, Zambia," *GeoHealth*, vol. 5, no. 1, 2021, DOI: 10.1029/2020GH000283.
- [2] N. Sinyange, J. M. Brunkard, N. Kapata, M. L. Mazaba, and K. G. Musonda, "Cholera Epidemic — Lusaka, Zambia, October 2017 – May 2018," vol. 67, no. 19, pp. 556–559, 2018.
- [3] J. Mwaba *et al.*, "Identification of cholera hotspots in Zambia: A spatiotemporal analysis of cholera data from 2008 to 2017," *PLoS Negl. Trop. Dis.*, vol. 14, no. 4, pp. 1–14, 2020, doi: 10.1371/journal.pntd.0008227.
- [4] K. S. Adu-Manu, C. Tapparello, W. Heinzelman, F. A. Katsriku, and J. D. Abdulai, "Water quality monitoring using wireless sensor networks: Current trends and future research directions," *ACM Trans. Sens. Networks*, vol. 13, no. 1, 2017, doi: 10.1145/3005719.
- [5] O. Chieochan, A. Saokaew, and E. Boonchieng, "IoT for the smart farm: A case study of the Lingzhi mushroom farm at Maejo University," *Proc. 2017 14th Int. Jt. Conf. Comput. Sci. Softw. Eng. JCSSE 2017*, 2017, doi: 10.1109/JCSSE.2017.8025904.
- [6] BRUVOLD WH and ONGERTH HJ, "Taste Quality of Mineralized Water," *Awwa-J*, vol. 61, no. 4, pp. 170–174, 1969, doi: 10.1002/j.1551-8833.1969.tb03732.x.
- [7] S. A. Obado, "IoT Based real-time fish pond water quality monitoring model," *Mestrado*, vol. 1, no. 73, 2019, [Online]. Available: <https://su-plus.strathmore.edu/handle/11071/6710>
- [8] S. Communication, "Relationship between Turbidity and Microbial Load of Water in Salman Farsi Dam Reservoir Relationship between Turbidity and Microbial Load of Water in Salman Farsi Dam Reservoir. J Environ Pollut Manage 2: 201," vol. 2, no. 2, pp. 2–5, 2019, [Online]. Available: www.scholarena.com
- [9] S. Pasika and S. T. Gandla, "Smart water quality monitoring system with cost-effective using IoT," *Heliyon*, vol. 6, no. 7, p. e04096, 2020, DOI: 10.1016/j.heliyon.2020.e04096.
- [10] N. Chaamwe, "Wireless sensor networks for water quality monitoring: A case of Zambia," *2010 4th Int. Conf. Bioinforma. Biomed. Eng. iCBBE 2010*, 2010, doi:10.1109/ICBBE.2010.5515792.
- [11] K. S. Adu-Manu, C. Tapparello, W. Heinzelman, F. A. Katsriku, and J.-D. Abdulai, "Water Quality Monitoring Using Wireless Sensor Networks," *ACM Trans. Sens. Networks*, vol. 13, no. 1, pp. 1–41, 2017, doi: 10.1145/3005719.
- [12] S. Pasika and S. T. Gandla, "Smart water quality monitoring system with cost-effective using IoT," *Heliyon*, vol. 6, no. 7, p. e04096, 2020, doi:10.1016/j.heliyon.2020.e04096.
- [13] N. Ya'acob, N. N. S. N. Dzulkefli, A. L. Yusof, M. Kassim, N. F. Naim, and S. S. M. Aris, "Water Quality Monitoring System for Fisheries using Internet of Things (IoT)," *IOP Conf. Ser. Mater. Sci. Eng.*, vol. 1176, no. 1, p. 012016, 2021, doi: 10.1088/1757-899x/1176/1/012016.
- [14] G. Chibuye, J. Phiri, and F. Banda, "A Spatial Framework for Managing Sewer and Water Networks Using Sensor Networks: A Case of the University of Zambia," *Int. J. Recent Contrib. from Eng. Sci. IT*, vol. 8, no. 1, p. 48, 2020, doi: 10.3991/ijes.v8i1.13983.
- [15] S. Verma and Prachi, "Wireless sensor network application for water quality monitoring in India," *2012 Natl. Conf. Comput. Commun. Syst. NCCCS 2012 - Proceeding*, pp. 237–241, 2012, DOI: 10.1109/NCCCS.2012.6412990.
- [16] J. P. R. Sorensen *et al.*, "Real-time detection of faecally contaminated drinking water with tryptophan-like fluorescence: defining threshold values," *Sci. Total Environ.*, vol. 622–623, pp. 1250–1257, 2018, doi: 10.1016/j.scitotenv.2017.11.162.
- [17] W. J. Hong *et al.*, "Water quality monitoring with Arduino based sensors," *Environ. - MDPI*, vol. 8, no. 1, pp. 1–15, Mar. 2021, doi: 10.3390/environments8010006.
- [18] F. M. Córdova, N. Troncoso, H. Díaz, F. Palominos, and L. Canete, "Design of a Decision-making Tool to Identify Cross-correlation Brain Dominances," *Procedia Comput. Sci.*, vol. 91, no. Itqm, pp. 65–74, 2016, doi: 10.1016/j.procs.2016.07.042.
- [19] S. A. H. Almetwally, M. K. Hassan, and M. H. Mourad, "Real Time Internet of Things (IoT) Based Water Quality Management System," *Procedia CIRP*, vol. 91, pp. 478–485, 2020, doi: 10.1016/j.procir.2020.03.107.
- [20] M. S. U. Chowdury *et al.*, "IoT based real-time river water quality monitoring system," *Procedia Comput. Sci.*, vol. 155, pp. 161–168, 2019, doi: 10.1016/j.procs.2019.08.025.
- [21] Godana, T., & Mukwena, R. M. (2004). Intergovernmental Relations and Fiscal Decentralisation in Namibia. Governance in Southern Africa and Beyond: Experiences of institutional and public policy Reform in Developing Countries. Windhoek: Gamsberg MacMillan, 85-110.
- [22] Mukwena, R. (2000). Crisis, Adjustment and Social Change in Zambia: The Case of Professionals. Lusaka, Zambia.
- [23] Mukwena, R. M. (2004). The Role of Decentralization in Reducing Regional Inequalities in Namibia. Regional Development Dialogue, 25, 108-128.
- [24] Mukwena, R. (2014). Decentralisation, democracy and development: The case of Zambia. 50 Years of Local Government in Zambia: Treasuring the Past, Reflecting the Present, Shaping the Future, 22-70.
- [25] Mukwena, R. M. (1999). Can local government performance be measured? Lessons from Zambia. *Africanus*, 29(1), 45-58.
- [26] Mukwena, R. M. (1998). The role of local councils in rural development: A study of Gwembe and Kalomo District Councils, Zambia, 1981-1995. The University of Manchester (United Kingdom).